



Editors network session #14

2024-01-30



Agenda

1. Round the table – what did you do recently? (web, digital content)
2. Images – their purpose, how to, regulations
3. Web / communications information
4. Digital accessibility and annual check reminder

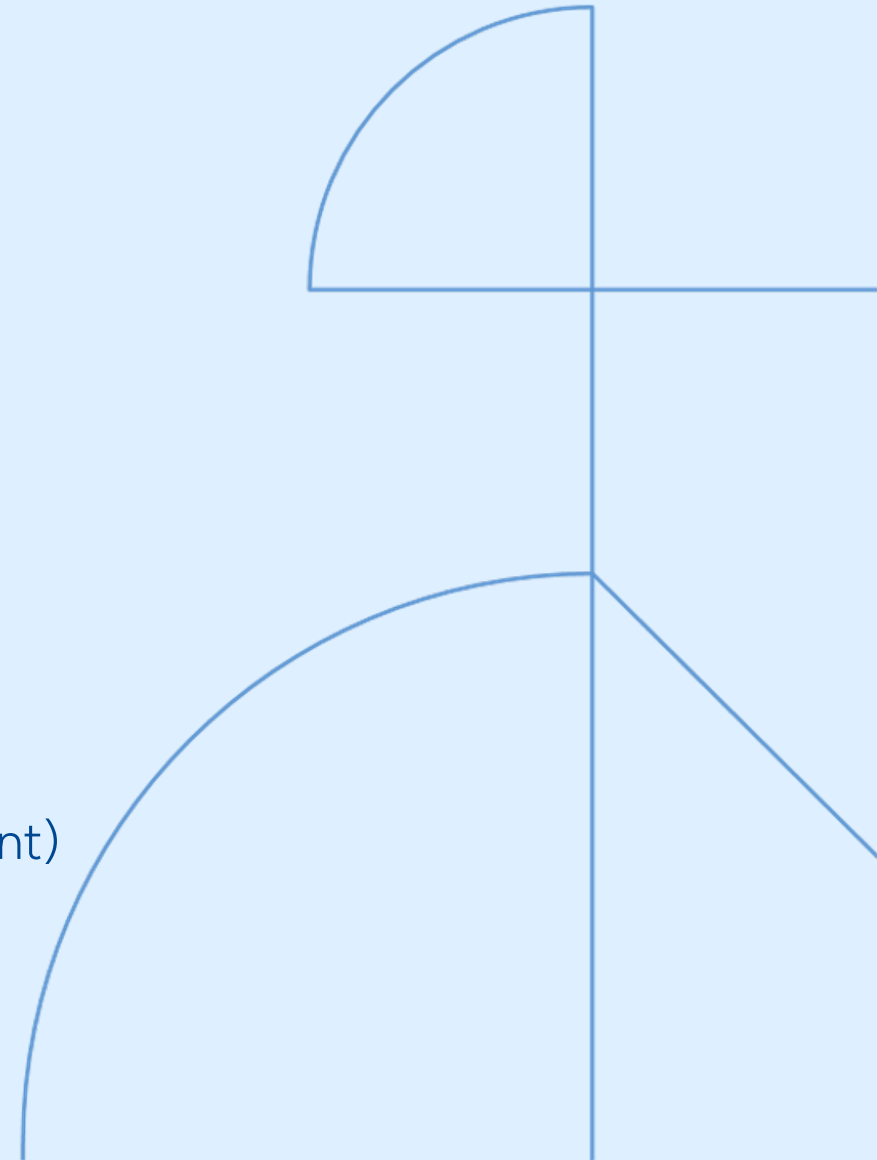



Visual communication

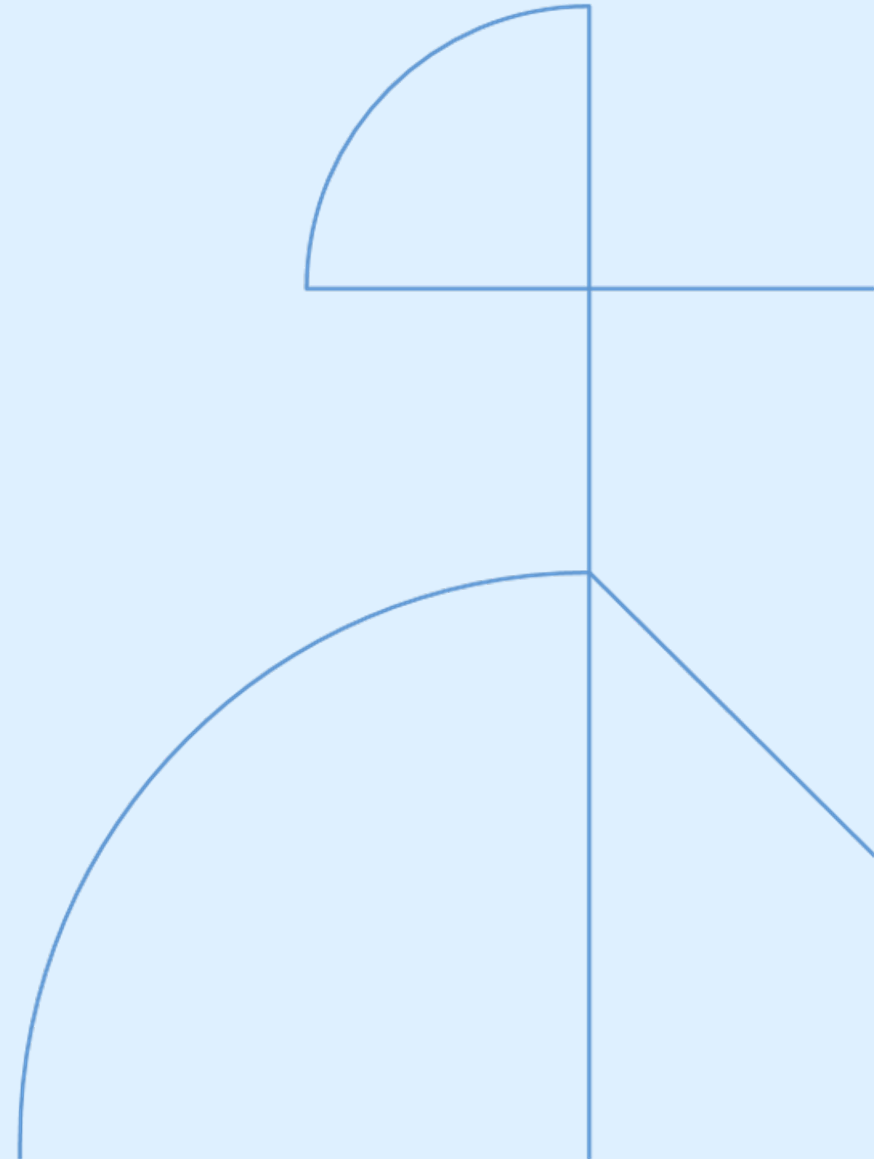

Event

- Interesting angels
- Diagonal
- Focus
- Think about equality, mix of genders, background, age.





- GDPR: "Shoot first, then ask" or Registration list as consent

List of participants and consent agreement

We will take photos at the event, and want to ensure that you agree to the publication of the images in KTH's channels.

By signing below, you give KTH consent to use the material indefinitely in the business, provided that the use of the material does not infringe or otherwise discredit you as a participant.

You transfer all photo and film rights to KTH and disclaim any copyright and financial claims.

You have the opportunity to use the material yourself in your own contexts.

For you who do not want to be in the picture, we ask you to choose the seats at the back of the room **or another designated place.**

Date	Name	Signature for consent	I DO NOT want to be in the pictures
Can be pre typed	Can be added in advance from the application list		

Research project

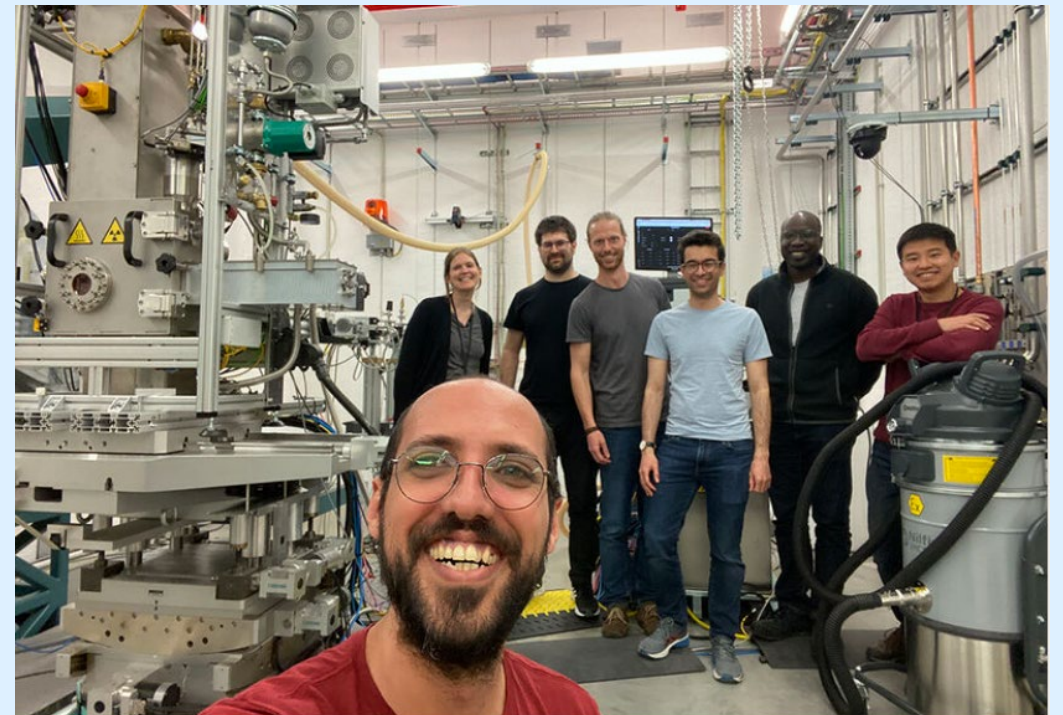



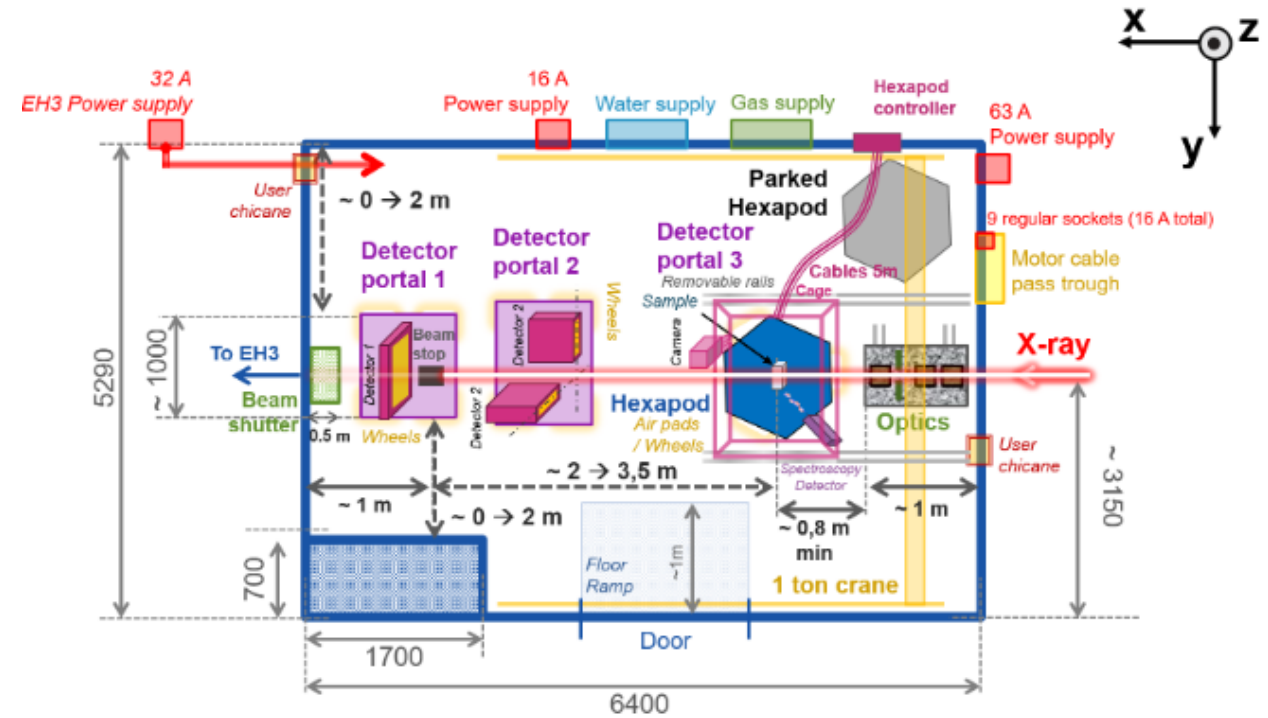

Experimental Hutch 2: Tenders welcome by 25 January

CeXS obtained funding to equip Experimental Hutch 2 at the Swedish Materials Science beamline, where extending the beamline's capability to support heavy-duty sample environments was a key design conc...

[Read the article](#)

A person





Several people



A specific occasion



A research finding, machine?

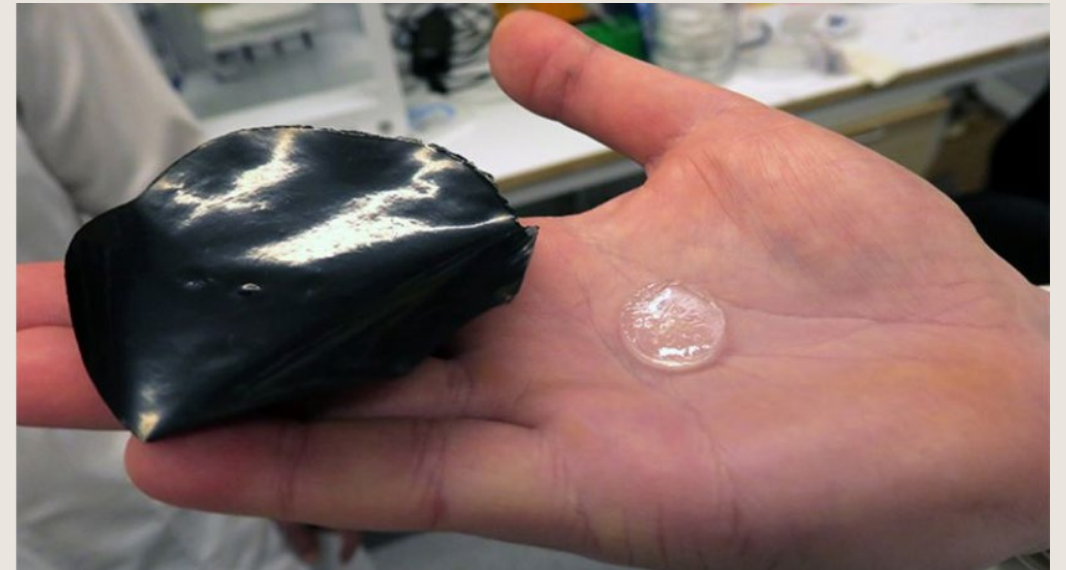

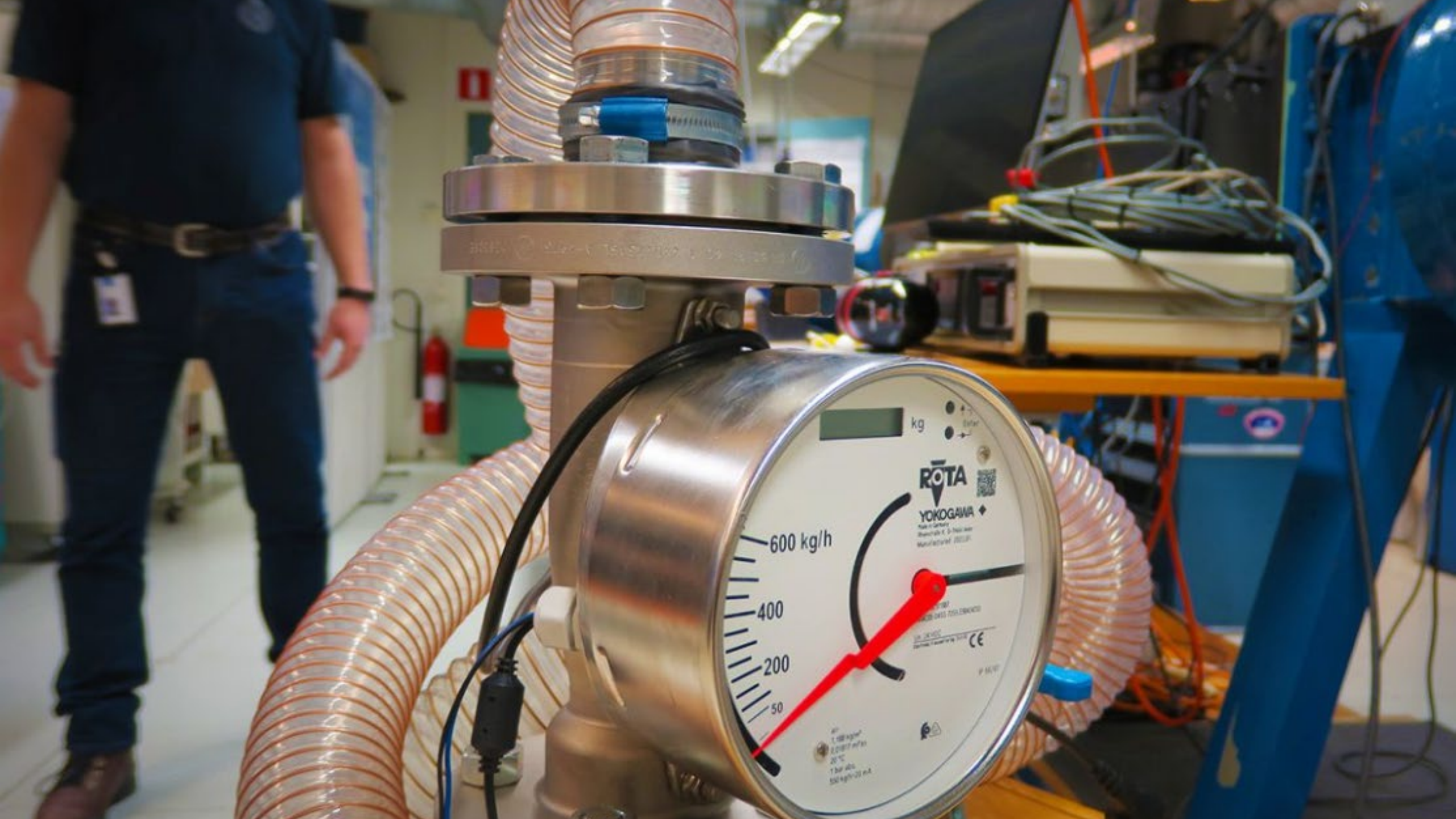

ROTA YOKOGAMA

kg

ROTA
YOKOGAMA

Flowmeter
Model: R-1000
Manufactured: 2023

600 kg/h

400

200

50

1 bar abs
100 kg/h/20 mA

CE

Students and other people outside KTH

- Model agreement is needed



Generic images

- Help the reader to quickly understand the impact, for instance.
- Drag attention.
- Finding generic images can be tricky
 - [Beautiful Free Images & Pictures | Unsplash](#)
 - [4.3 million+ Stunning Free Images to Use Anywhere - Pixabay – Pixabay](#)
 - [Free Stock Photos, Royalty Free Stock Images & Copyright Free Pictures · Pexels](#)
- Remember to add the photo credits in the caption.

Rising global temperatures raise the risk of premature deterioration and failure in products made of polymeric material. In an article published in Science, KTH researcher [Xinfeng Wei](#) and Professor [Mikael Hedenqvist](#) are calling fo ...see more



Risks with image banks

- Cliché
- Does not suit a Nordic context
- Over use
- Does not feel KTH



Another cliché to avoid: Men at the office, women in the nature

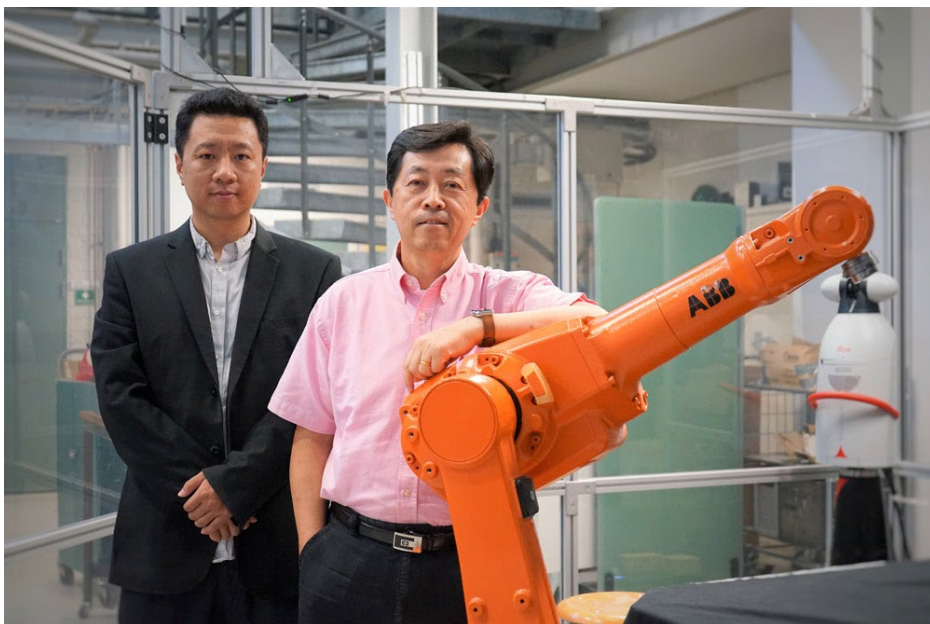

KTH media bank

- [KTH Mediabank \(mediaflowportal.com\)](https://mediaflowportal.com)
- [E-mail grafiskprofil@kth.se](mailto:grafiskprofil@kth.se) to get access.

Nya filer Endast filer med previewstöd visas

Idag, 48 h, 7 dgr

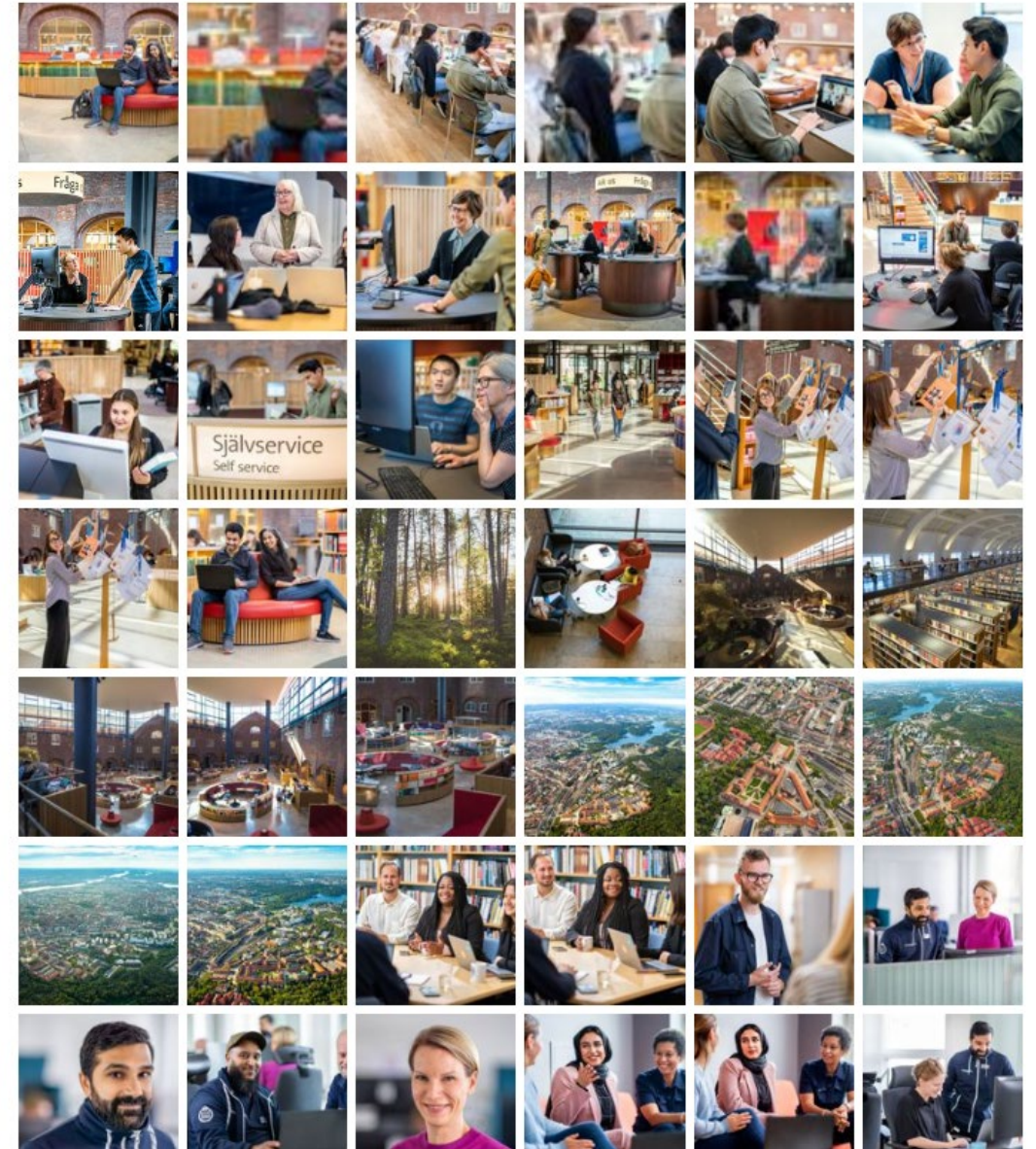

Express a feeling?



The elements of the image - composition

- Gyllene snittet / Golden ratio

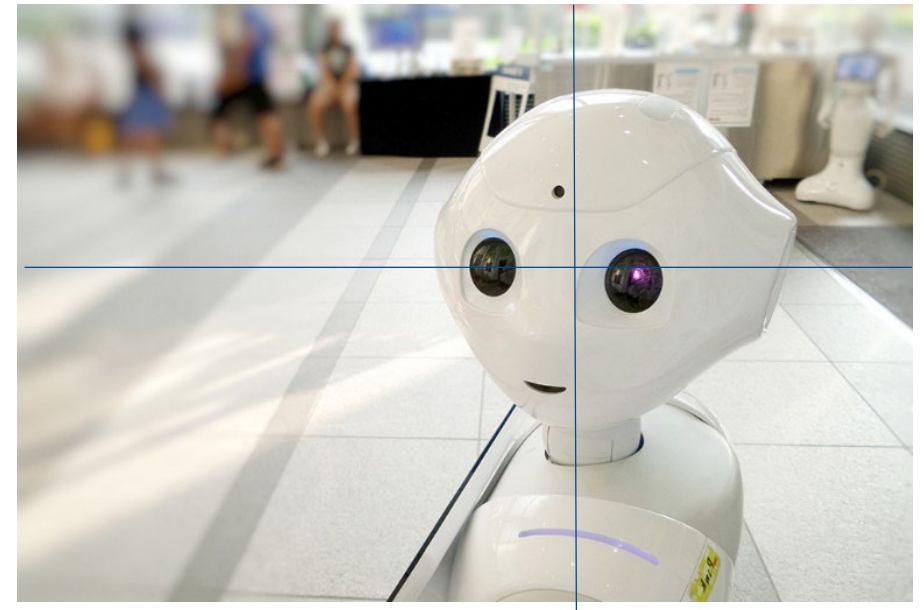
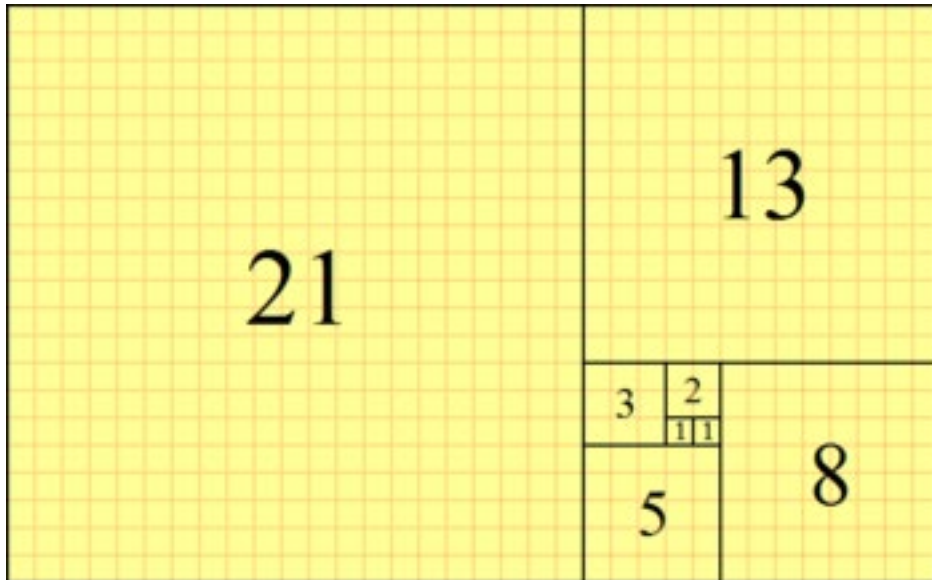

The elements of the image - contrasts

- Small – large
- Dark – bright
- Natural – artificial

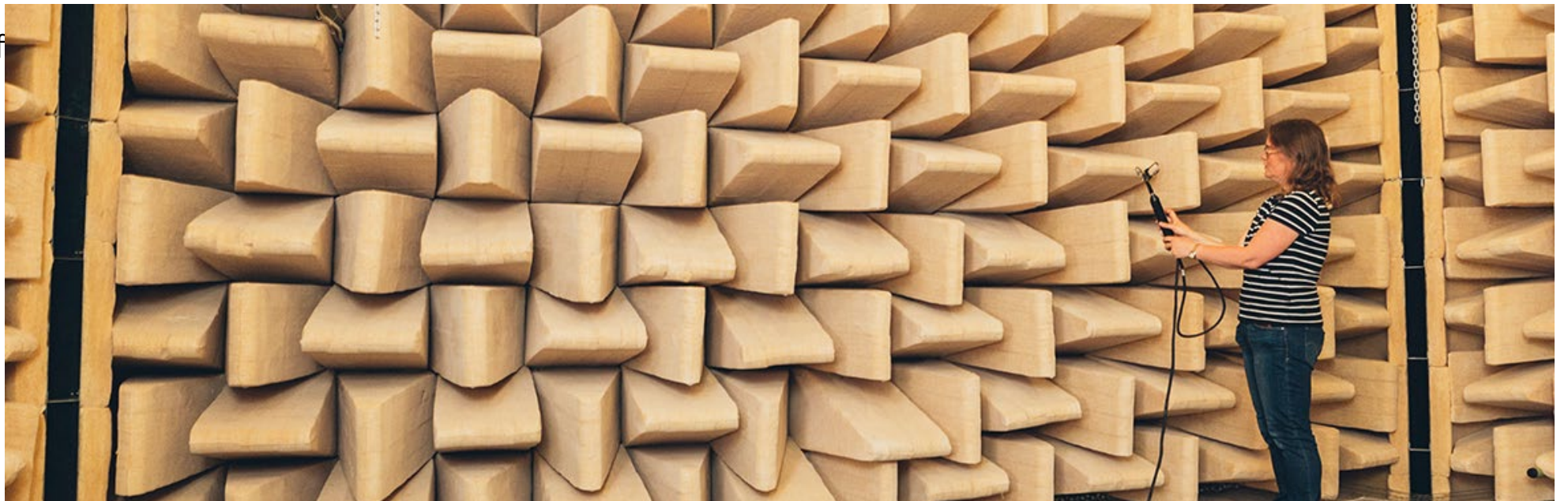

Learn more about how to take the picture

[I Shot 100,000 Portraits: Here's What I Learned... \(youtube.com\)](#)

[8 IMPORTANT Composition Tips for Better Photos \(youtube.com\) – 2:15](#)



Information

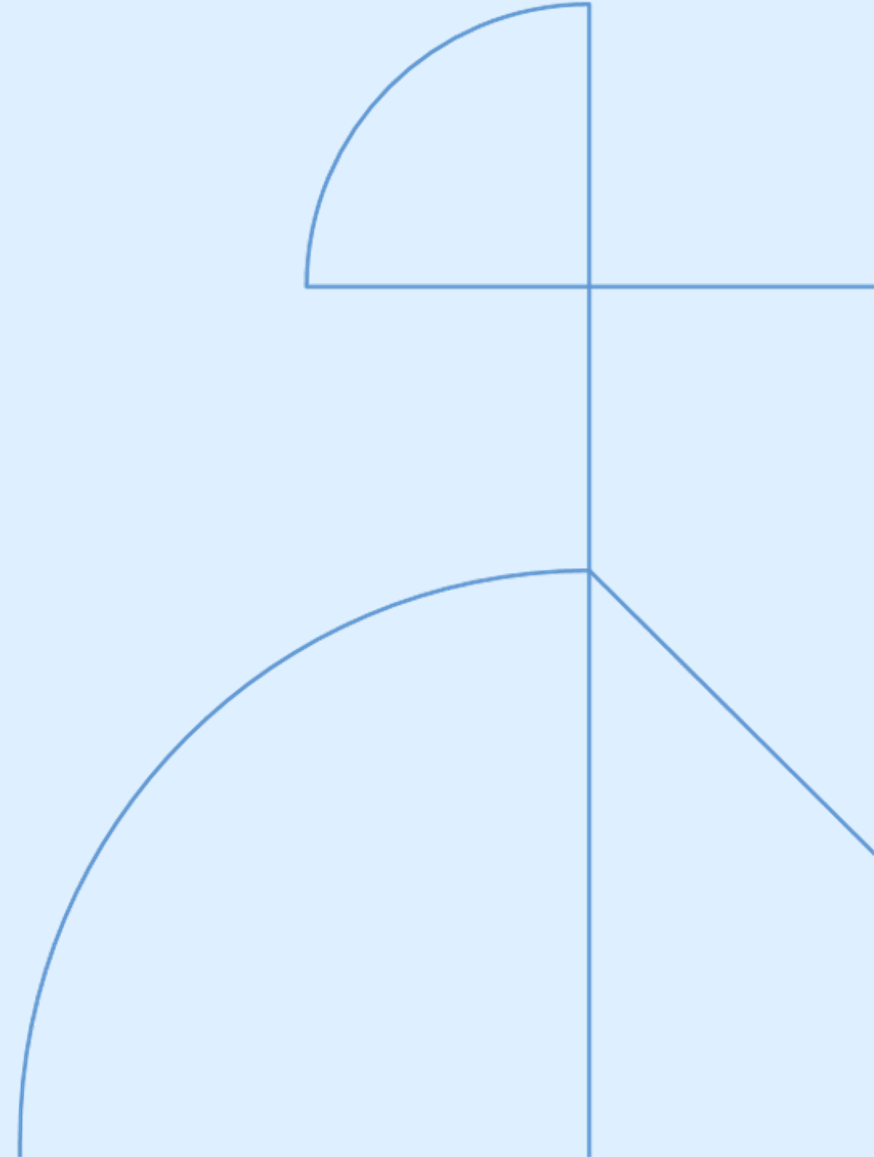

What's going on?

- New graphic profile online delayed. Q1
- Lack of developers at KTH IT
- A new search service on KTH.se
 - Avtal med nuvarande leverantör går ut sommaren 2024. Vi avser att inte förlänga.
 - Utvärdering av integration med s k allmän söktjänst. Bing huvudspår då vi har infrastruktur för Microsoft-baserade molntjänster
 - Lansering våren 2024
- Reorganising administrative support:
 - From 1 April communications will merge into one division.
 - We might get new managers, but will keep our
- LinkedIn pages for your news:
 - Materials
 - Energy
 - Digitalisation
 - Cities

[Read more: Topic based pages on LinkedIn | KTH Intranet](#)

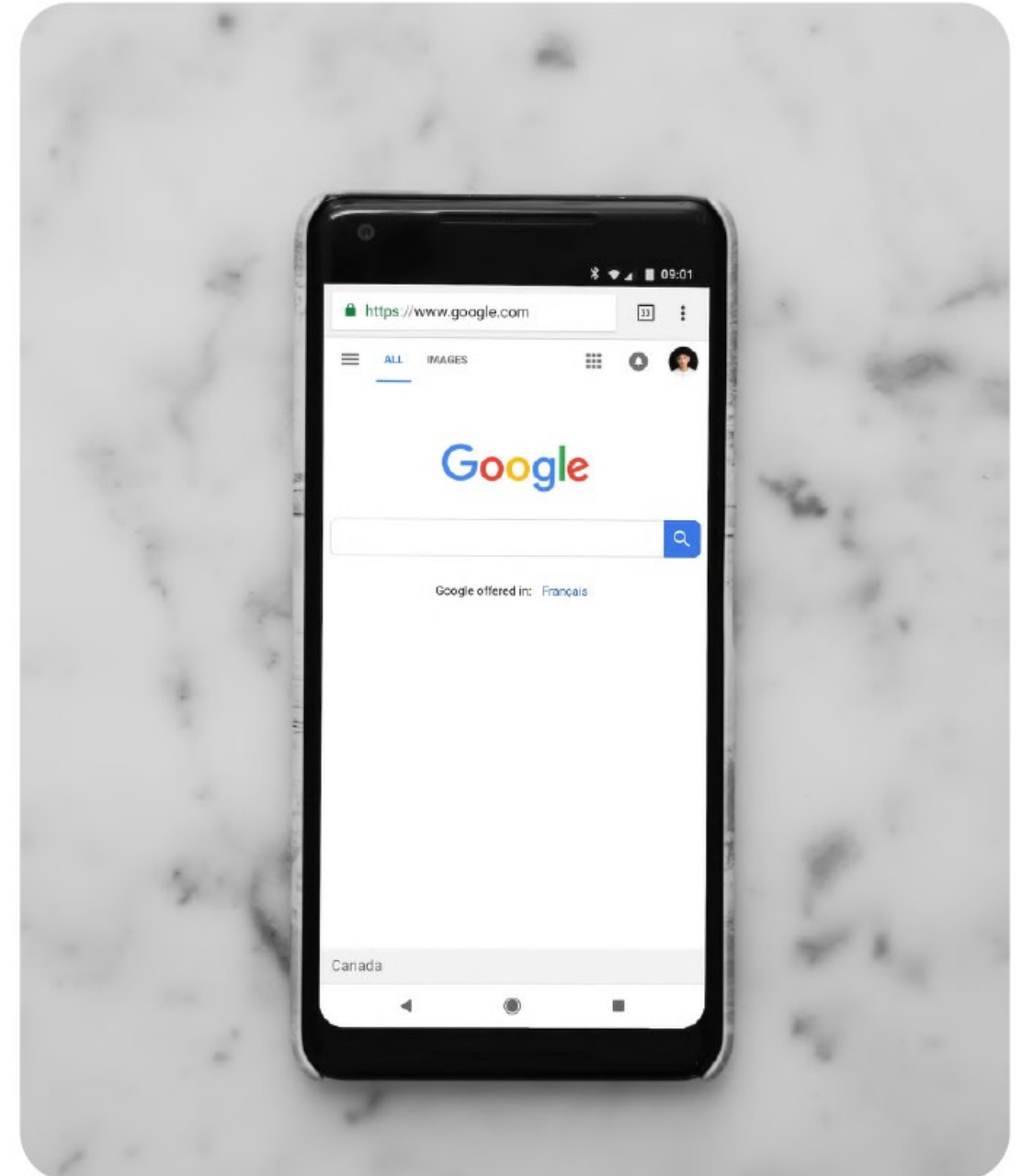

AI tools

- [ChatGPT](#)
- [DeepL](#)
- [Bing's Copilot](#)



How can I help you today?

Suggest fun activities

for a family of 4 to do indoors on a rainy day

Give me ideas

about how to plan my New Years resolutions

Create a personal webpage for me

after asking me three questions

Recommend a dish

to impress a date who's a picky eater

Message ChatGPT...

SEO and digital accessibility

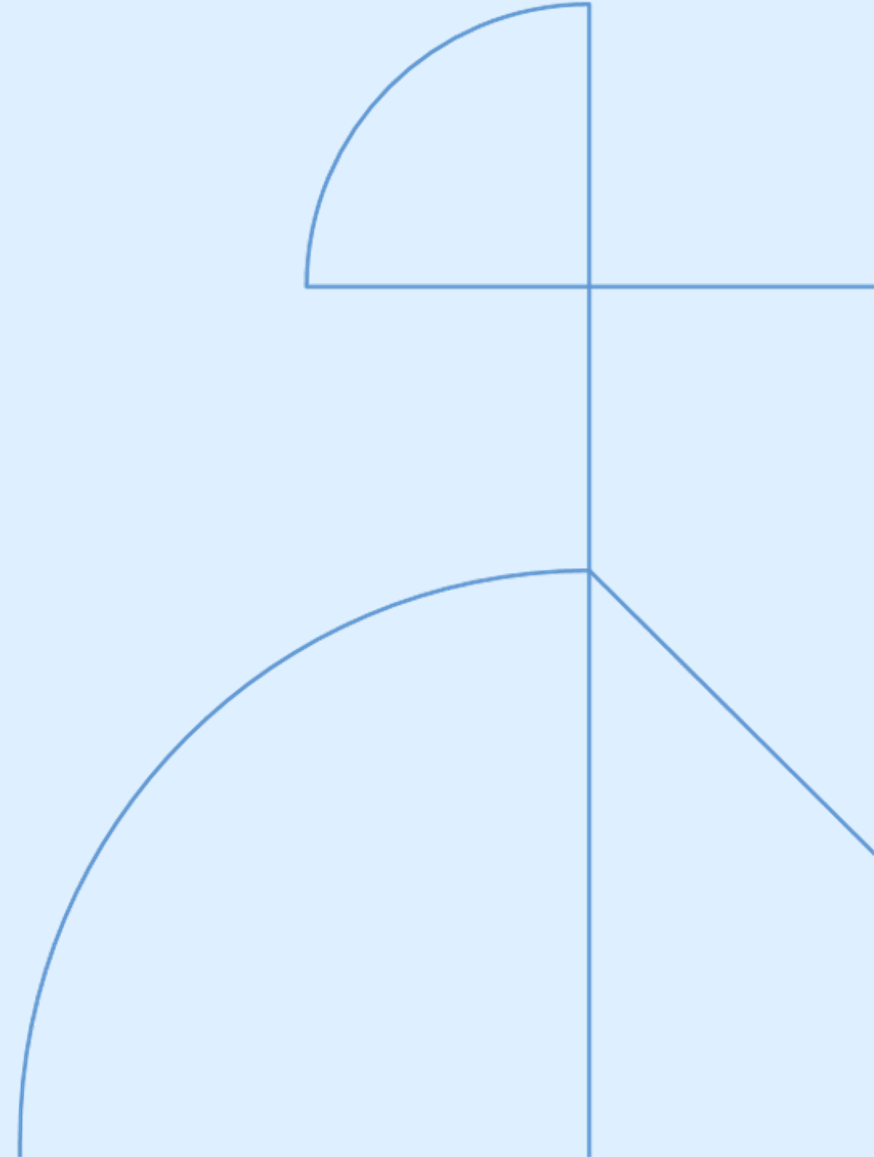

What can we editors wo?

Se till att:

- innehållet är **relevant**
- innehållet är **unikt**
- **läsbarheten** är god
- innehållet är **uppdaterat**
- **återanvända** sidor när du ska uppdatera innehållet
- **länka** till relaterat innehåll på vår webbplats och externa webbplatser

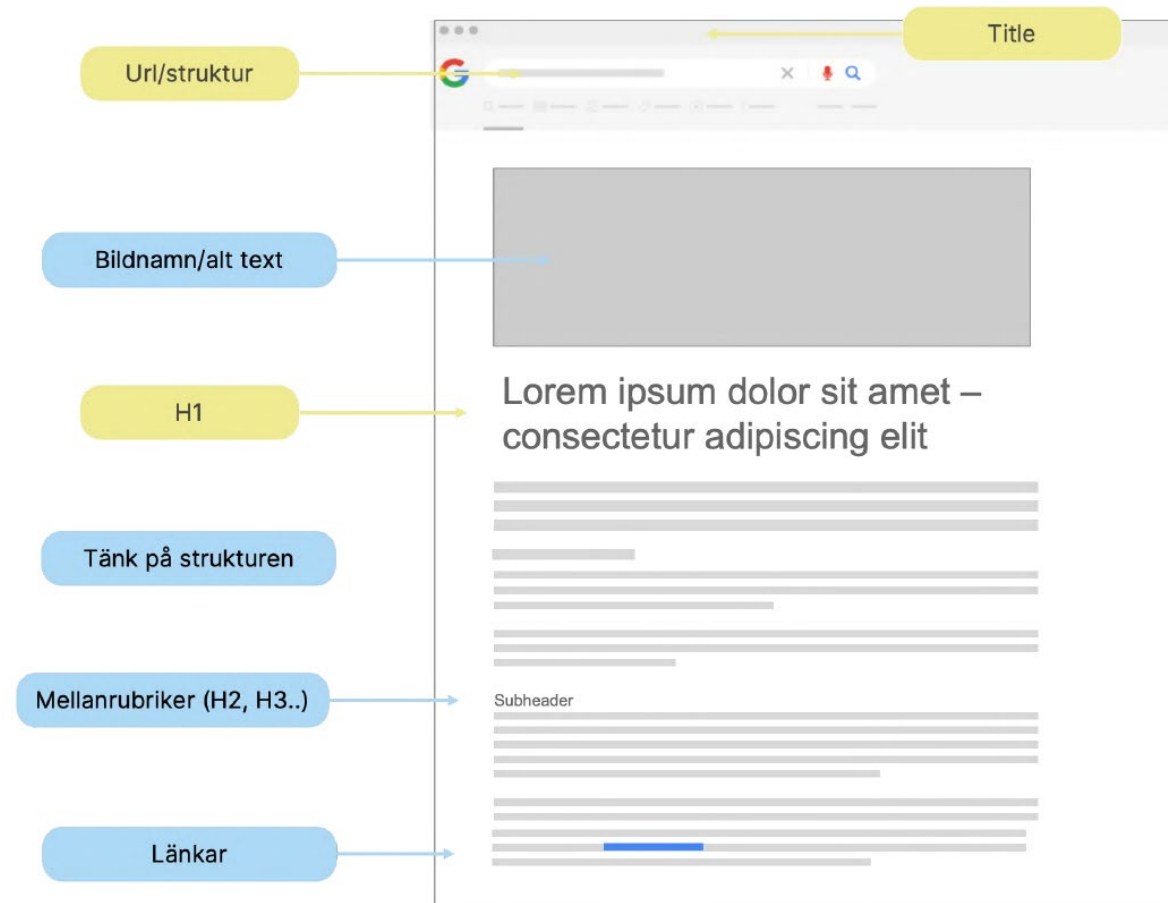

Digital accessibility

- [Digital accessibility - requirements and opportunities | KTH Intranet](#)
- [Canvas course Digital@KTH](#)
- Remember:
 - Describing links. ~~Read more, click here~~
 - Alt texts on all images except for decorative ones
 - Headings in the right order, H1, H2, H3.
 - Structure the text with bullet lists, paragraphs, sub headings.
 - Use a plain language.

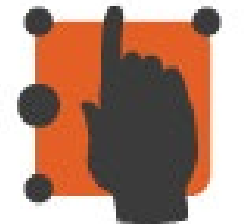

Want to learn more about SEO?



Guides

Läs mer på intranätet [Sökmotoroptimering \(SEO\)](#)

Checklist and more advise on web editing

[Advice to the ITM web editors](#)

Tack för att ni deltog!

Ulrika Georgsson
Communications Officer &
Coordinator of the ITM
School's websites

ulrikage@kth.se

[087907635](tel:087907635)

[Profile](#)

